

# P-350iA/45



Max. load capacity  
at wrist: **45 kg**



Max. reach:  
**2606 mm**

Controlled axes	Repeatability (mm)	Mechanical weight (kg)	Motion range [°]						Maximum speed [°/s]						J4 Moment/ Inertia (Nm/kgm <sup>2</sup> )	J5 Moment/ Inertia (Nm/kgm <sup>2</sup> )	J6 Moment/ Inertia (Nm/kgm <sup>2</sup> )
			J1	J2	J3	J4	J5	J6	J1	J2	J3	J4	J5	J6			
6	± 0.1	590	360	225	440	800	250	800	180	180	180	250	250	360	206/28	206/28	127/20

## Working range

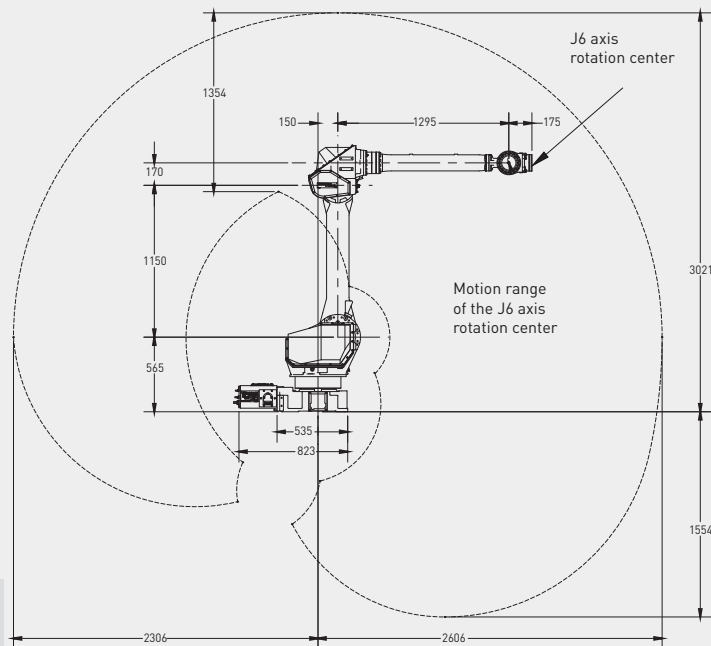
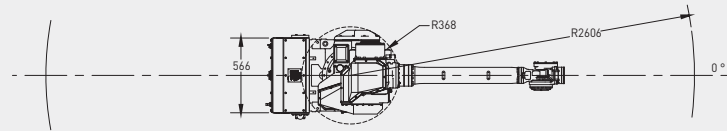

Maximum work envelope is restricted for mounting angles > 42°

## Robot

Robot	P-350iA/45
Robot footprint [mm]	535 x 550 (823 x 566**)
Mounting position Floor	•
Mounting position Invert	-
Mounting position Wall	-
Mounting position Angle	•

## Controller

Controller	R-30iB Plus
Open air cabinet	-
Mate cabinet	-
A-cabinet	•
B-cabinet	-
iPendant	•
ISTP option	-

## Electrical connections

Voltage 50/60Hz 3phase [V]	380-575
Voltage 50/60Hz 1phase [V]	-
Average power consumption [kW]	2.5

## Integrated services

Integrated signals on upper arm In/Out	-
Integrated air supply	2

## Environment

Acoustic noise level [dB]	71.3
Ambient temperature [° C]	0-45

## Protection

Hazardous location certification	*6
----------------------------------	----

\*6) Class I, II, III Div. I Group C, D, E, F, G  
ATEX CE II 2 G c Ex ib px IIB T4 Ta = 0°C to +45°C  
ATEX CE II 2 D c Ex pD 21 T135°C Ta = 0°C to +45°C

\*\* including purge box

• standard ○ on request - not available ( ) with hardware and/or software option